



CONVENTION CONTRACTORS, INC.

57 NE 179TH STREET, MIAMI, FLORIDA 33162
TEL: 305/751-1234 FAX: 305/751-1298

EXPO QUICK FACTS

SHOW NAME: THE INTERNATIONAL CONGRESS OF ESTHETICS & SPA

SHOW DATES: March 22-23, 2009

SHOW LOCATION & ROOM/HALL: Arlington Convention Center

DEADLINE DATE TO RECEIVE DISCOUNTED RATES: March 6, 2009

EXHIBITOR MOVE-IN:	Saturday,	March 21, 2009	8:00am - 5:00pm
SHOW HOURS:	Sunday,	March 22, 2009	9:00am - 6:00pm
	Monday,	March 23, 2009	9:00am - 5:00pm
EXHIBITOR MOVE-OUT:	Monday,	March 24, 2009	5:00pm - 9:00pm
	Tuesday,	March 25, 2009	8:00am - 12noon

MOVE-OUT NOTE: All carriers must check in before Tuesday, March 25, 2009, 9:00am.

OVERTIME CHARGES:

Please be advised that overtime charges will apply during MOVE IN and MOVE-OUT on Monday.

SHOW COLORS:

Back Drape: White
Side Drape: White
Table Drape: White

BOOTH EQUIPMENT:

Each 10' x 10' booth area will be provided with an 8' high background drape, 3' high side drape, one 6' draped table, 2 chairs, 1 wastebasket, booth Identification sign (7" x 44") and Grey booth carpet.

CARPET COLOR:

Grey booth carpet is included in your booth package. The aisle carpet will be grey also.

ADVANCE WAREHOUSE SHIPMENT:

Materials should be shipped to Arrive at our warehouse NO LATER THAN March 13, 2009. Freight received after this date will incur a 25% late fee.

Show Name Company Name Booth #
EXPO Convention Contractors, Inc.
c/o UPS Freight Service Center
5001 David Strickland Road
Arlington, TX 76119

See our Shipping & Drayage form for complete details.

DIRECT SHIPMENT TO FACILITY:

Shipments will be received at the exhibit facility on Saturday, March 21, 2009 between 8:00am - 5:00pm.

Show Name Company Name Booth #
EXPO Convention Contractors, Inc.
c/o Arlington Convention Center
1200 Ballpark Drive East
Arlington, TX 76011

See our Shipping & Drayage form for complete details.

ASSISTANCE:

We want you to have a successful show. If we can be of assistance, please call our Exhibitor Sales & Services Department at 305.751.1234.



CONVENTION CONTRACTORS, INC.

57 NE 179TH STREET, MIAMI, FLORIDA 33162
TEL: 305/751-1234 FAX: 305/751-1298

IMPORTANT DATED MATERIAL

**THE INTERNATIONAL CONGRESS OF ESTHETICS & SPA
ARLINGTON CONVENTION CENTER
MARCH 22-23, 2009**

DEAR EXHIBITOR,

EXPO Convention Contractors, Inc. is pleased to provide complete exhibitor services for THE INTERNATIONAL CONGRESS OF ESTHETICS & SPA, March 22-23, 2009 in Arlington, Texas. In our commitment to promise an enjoyable and smooth-running event, this EXPO Exhibitor Service Kit has been prepared for your use in planning your exhibit. *Please review the following information carefully and place orders early to save time, money and worry!*

Each 10' X 10' Booth Package will include:

- 8' High Backwall and 3' High Side Drapery in White
- 1 – 6' Skirted Table - White
- 2 – Chairs
- 1 – Exhibitor Identification Sign
- 1 – Wastebasket
- 1 – Grey Booth Carpet

Move-in and Move-Out Schedule:

Exhibitor Set Up:	Saturday,	March 21, 2009	8:00am - 5:00pm
Show Opens:	Sunday,	March 22, 2009	9:00am - 6:00pm
	Monday,	March 23, 2009	9:00am - 5:00pm
Exhibitor Dismantle:	Monday,	March 24, 2009	5:00pm - 9:00pm
	Tuesday,	March 25, 2009	8:00am - 12noon

ADVANCE ORDER DEADLINE

To take advantage of discounts, advance orders must be paid in full and received with payment no later than **March 6, 2009**. *We must have a major credit card on file to process your orders!* Please complete the Payment Policy Form in its entirety with correct information. EXPO Exhibitor Order Forms must be returned to our Miami office and can be faxed directly to 305-751-1298. Order forms for electrical, audio/visual, telephone etc. should be returned to the specific contractor providing these services.

IMPORTANT SHIPPING PROCEDURES

EXPO recommends shipping exhibit materials up to 30 days in advance prior to the event to our *Advance Freight-Receiving Warehouse*. Making advanced shipping arrangements will ensure a prompt and secure delivery to your exhibit site! The event's location will not have the facilities to receive and store such materials in advance and may refuse your shipment and/or additional charges may be incurred.

For Advance Shipping to Warehouse: All freight shipments must be shipped prepaid and received in our warehouse no later than **March 13, 2009**. *A 25% late charge will apply if orders for advance shipping are received after this date.*

For Direct Shipping to Show Site: Please DO NOT ship exhibit materials directly to show site to arrive prior to **March 21, 2009**. *You must designate your shipments for arrival during exhibitor set-up date only and label your materials "In Care of EXPO Convention Contractors, Inc."*

Please call our **Exhibitor Sales & Services Department at 305-751-1234** for any questions we may assist you with. We look forward to working with you and wish you a very successful event!

Sincerely,
EXPO Convention Contractors, Inc.
Nancy Stewart



CONVENTION CONTRACTORS, INC.
 57 NE 179TH STREET, MIAMI, FLORIDA 33162
 TEL: 305/751-1234 FAX: 305/751-1298

THE INTERNATIONAL CONGRESS
 OF ESTHETICS & SPA
 ARLINGTON CONVENTION CENTER
 MARCH 22-23, 2009

DEADLINE: MARCH 6, 2009

****PAYMENT POLICY****

**NO SERVICES WILL BE RENDERED UNTIL THIS DOCUMENT IS COMPLETED,
 SIGNED AND RETURNED TO EXPO**

ADVANCE AND/OR FLOOR ORDERS: All Orders require ADVANCE PAYMENT for initial estimate of charges for services AND a VALID CREDIT CARD with proper authorization be provided to EXPO. You may prepay with a check written on your company, but a credit card is required by EXPO to ensure any unexpected charges, such as additional freight, clean up costs, etc, are paid at the time the Show closes.

THIRD PARTY ORDERS: If you choose to contract work to a Display or Exhibit house/company and/or require services from EXPO, the Payment Policy presented above shall apply. EXPO must be notified, in writing, from exhibiting company of any other display or exhibit company involved in the set up or breakdown of exhibits.

DRAYAGE TO WAREHOUSE OR SHOW SITE AND/OR LABOR: EXPO's Payment Policy must be adhered to by Exhibitor prior to any freight being shipped to EXPO. All charges for freight, assembling, disassembling, shipping, handling and any other must be prepaid. If adjustments or additional charges are required at Show Close they will be charged to the enclosed Credit Card provided, unless Exhibitor disputes charges in writing. EXPO is **not responsible** for any damage or loss of your freight, please secure round trip insurance from your company insurance carrier.

ALL CHARGES: All charges/costs requested by Exhibitor MUST be PAID IN FULL before services are rendered, and any adjustment and/or additional charges must be paid by Show Close. Such costs will be charged to Exhibitor's credit card provided unless prior arrangements have been made. All checks must be drawn on a U.S. bank, and there will be a minimum charge of \$25 for each NSF check written to EXPO.

ADJUSTMENTS: Exhibitors are responsible for ensuring services are rendered as ordered prior to the Show opening. All requests for adjustments must be made on site prior to the Show's closing. EXPO will not be responsible for adjustments after the Show closes unless prior arrangements have been agreed to in writing by EXPO.

SALES TAX: Applicable city, county and state sales tax will apply. If any Exhibitor is exempt from paying sales tax, it is the Exhibitor's responsibility to provide EXPO with its tax exempt number prior to beginning of show.

CANCELLATION POLICY: In the event of a natural disaster, acts of God or terrorists, which result in the cancellation of this event, EXPO will be entitled to a fee equal to the percentage of work completed by EXPO. This percentage will be determined solely by EXPO. In the event the deposit received exceeds the percentage of work completed, EXPO will refund the excess deposit.

COLLECTION POLICY: In the event this contract is turned over to an attorney for collection or dispute, EXPO will be entitled to reasonable attorney fees.

RETURN VIA FAX: 305-751-1298

We accept American Express, Visa, MasterCard and DiscoverCard for your convenience.

Exhibitor _____ Booth _____
 Address _____
 City _____ State _____ Zip _____
 Phone _____ Fax _____
 Email _____ Contact/s _____
 Credit Card Used For Payment: No. _____ Expires _____
 Security Code _____ (The 3 numbers on back of card or for Amex the 4 numbers on the front)
 Billing Address for credit card: _____
 Credit Card Holder (Print Name) _____ Signature _____
 List Persons Authorized to Incur Charges on Credit Card _____

******Cardholder hereby authorizes EXPO to charge credit card described herein for all charges incurred by Exhibitor and has read, understands, and agrees to all forms in the exhibitor manual and agrees to pay all charges as described in Cardholder Agreement. All estimated charges must be paid in ADVANCE, AND a valid credit card must be on file with EXPO authorizing payment for modified and/or additional charges. All Charges must be paid by end of Show.**



CONVENTION CONTRACTORS, INC.
 57 NE 179TH STREET, MIAMI, FLORIDA 33162
 TEL: 305/751-1234 FAX: 305/751-1298

**THE INTERNATIONAL CONGRESS
 OF ESTHETICS & SPA
 ARLINGTON CONVENTION CENTER
 MARCH 22-23, 2009**

DEADLINE: MARCH 6, 2009

RENTAL FURNISHINGS

QTY	CHAIRS	ADVANCE PRICE	FLOOR PRICE	AMOUNT
	UPHOLSTERED ARM CHAIR	50.00	60.00	
	UPHOLSTERED SIDE CHAIR	44.00	63.00	
	EXECUTIVE SWIVEL ARM CHAIR	105.00	127.00	
	PADDED COUNTER STOOL W/BACK	99.00	121.00	
PEGBOARDS/TACK BOARDS				
	4' x 8' PEGBOARD	94.00	105.00	
	2' x 8' PEGBOARD	61.00	72.00	
	4' x 6' TACKBOARD	94.00	105.00	
INSTALL (Please Check type needed):				
VERTICALLY _____ HORIZONTALLY _____ PEGBOARDS DO NOT INCLUDE HOOKS OR BRACKETS				
ACCESSORIES				
	DELUXE DESK	330.00	413.00	
	EASEL	26.00	30.00	
	WASTEBASKET	28.00	33.00	
	COFFEE TABLE 20"x36"x15" HIGH	55.00	66.00	
	ROUND TABLE 30" x 30" HIGH	135.00	174.00	
	ROUND TABLE 30" x 42" HIGH	155.00	194.00	
	ALUMINUM STANCHION 8' HIGH	19.00	27.00	
	AISLE STANCHION 3' HIGH	19.00	27.00	

SPECIAL DRAPERY	
_____ FEET OF 8' HIGH DRAPE AT \$14.00 PER LINEAR FOOT	
_____ FEET OF 3' HIGH DRAPE AT \$9.00 PER LINEAR FOOT	

QTY	TABLES	ADVANCE PRICE	FLOOR PRICE	AMOUNT
	4TH SIDE DRAPED	39.00	50.00	
CIRCLE COLOR:	GOLD WHITE RED PEACH BLUE TEAL BLACK BURGUNDY GREY			
	2' X 4' TABLES - 30" HIGH	105.00	116.00	
	2' x 6' TABLES - 30" HIGH	116.00	138.00	
	2' X 8' TABLES - 30" HIGH	138.00	160.00	
	42" COUNTER HEIGHT TABLES ADD PER TABLE	44.00	55.00	
<i>ALL TABLES AVAILABLE UNDRAPED AT 25% OFF DRAPED TABLE PRICES LISTED ABOVE</i>				
TABLE RISERS				
	4' X 8" X 8" ONE STEP	44.00	61.00	
	4' X 8" X 16" TWO STEP	55.00	66.00	
	6' X 8" X 8" ONE STEP	55.00	66.00	
	6' X 8" X 16" TWO STEP	66.00	83.00	
CARPETING				
CIRCLE COLOR:	RED BLUE GREY BURGUNDY TEAL			
	9' x 10'	99.00	127.00	
	9' x 20'	204.00	231.00	
	9' x 30'	303.00	358.00	
CARPETING CUT & TAILORED TO FIT SPACE PRICE INCLUDES LAYING, CUTTING, TAPING SEAMS, AT \$3.75 PER SQ. FT.				
_____ X _____				
	RUG TAPE PER FT.	2.00		
	CARPET PADDING PER SQ.FT	.90		

Sub Total	_____
8.25% Sales Tax	_____
GRAND TOTAL	_____

No credit will be issued on equipment ordered and placed in your booth, even though not used. There is a 25% cancellation charge for orders cancelled at show-site before they are placed in your booth. All materials are on a rental basis and remain the property of EXPO. The undersigned is responsible for all items ordered and for its condition at close of Show. If items are damaged or destroyed, in EXPO's sole judgment, Exhibitor hereby authorizes EXPO to charge the replacement costs of such item/s to the credit card contained herein. Listed charges include delivery to booth, rental for duration of show and removal. Before an Order is accepted, Exhibitor must have a valid credit card on file with EXPO with sufficient amounts authorized for payment of all charges by Exhibitor during Show. Exhibitor / Cardholder***** hereby authorizes EXPO to charge credit card described herein for all charges incurred by Exhibitor and agrees to pay all charges as described in Cardholder Agreement. All estimated charges must be paid in ADVANCE of services being rendered, AND cardholder hereby authorizes EXPO to charge any modified and/or additional charges. All charges must be paid by end of show. Initial estimate of charges MUST be paid, either by check or credit card, at time Order is placed.

Company Name _____ Booth _____

Contact Name _____

Address _____

City _____ State _____ Zip _____

Phone _____ Fax _____

RETURN VIA FAX: 305-751-1298



CONVENTION CONTRACTORS, INC.
 57 NE 179TH STREET, MIAMI, FLORIDA 33162
 TEL: 305/751-1234 FAX: 305/751-1298

THE INTERNATIONAL CONGRESS
 OF ESTHETICS & SPA
 ARLINGTON CONVENTION CENTER
 MARCH 22-23, 2009

DEADLINE: MARCH 6, 2009

STS Rental Exhibit Order Form *SPACE TECH SYSTEM*

PLEASE ENTER YOUR ORDER FOR RENTAL DISPLAY MODULE UNITS AS SPECIFIED BELOW.
 ALL ELECTRICAL AND UTILITY CHARGES ARE DIRECT BILLED TO EXHIBITOR BY ELECTRICAL CONTRACTOR.

Your Choice Hardwall Unit or Velcro Unit - STS 101 - 300 **ONLY**

Unit #	Advance Price	Standard Price	White PVC Only	Carpet	TOTAL
STS 100	\$1,788.00	\$ 2,159.00	Please choose one of the following for STS 101 - 203: White PVC Panel _____ Grey PVC Panel _____ Black PVC Panel _____ Blue PVC Panel _____ Grey Velcro Panel _____ For STS 300 - 400 call 305-751-1234 ext 245	<input type="checkbox"/> Gray	\$ _____
STS 101	\$2,167.00	\$ 2,654.00		<input type="checkbox"/> Teal	\$ _____
STS 102	\$2,577.00	\$ 3,193.00		<input type="checkbox"/> Blue	\$ _____
STS 103	\$2,621.00	\$ 3,274.00		<input type="checkbox"/> Burgundy	\$ _____
STS 200	\$4,268.00	\$ 5,335.00		<input type="checkbox"/> Black	\$ _____
STS 201	\$4,955.00	\$ 6,303.00			\$ _____
STS 203	\$5,362.00	\$ 6,598.00			\$ _____
STS 300	\$6,341.00	\$ 7,595.00			\$ _____
STS 400	\$9,020.00	\$10,989.00			\$ _____

**PAYMENT & CANCELLATION POLICY: Payment is required at time of Order.
 Funds are not reimbursable should order be cancelled.**

 (INSERT HEADER SIGN COPY IN BOX) BLACK HELVETICA LETTERS ARE STANDARD

QUANTITY	We request _____ Rental Exhibits	*****@ \$ _____ = _____
_____	White cabinet (77"l x 39"h x 18"d) with sliding doors	Advance Standard
_____	(without STS Exhibit).....	@ \$234.00 \$301.00 = _____
_____	White cabinet 39"l x 39"h x 18"d) with sliding doors	@ \$282.00 \$356.00 = _____
_____	(without STS Exhibit)	@ \$192.00 \$246.00 = _____
_____	Side rail as shown (set of 2)	@ \$240.00 \$305.00 = _____
_____	Additional white shelves and brackets	@ \$165.00 \$205.00 = _____
_____	Velcro panel for STS Standard.....	@ \$ 32.00 \$ 40.00 = _____
_____	Pegboard Panel.....	@ \$125.00 \$155.00 = _____
_____	Slat-Wall Panel	@ \$125.00 \$155.00 = _____
_____	Special Color Panels	@ \$225.00 \$280.00 = _____
_____	Lock for Cabinets per cabinet.....	@ \$147.00 \$190.00 = _____
		@ \$ 22.00 \$ 31.00 = _____
	Total all Items	\$ _____
	8.25% Sales Tax	\$ _____
	Balance Due	\$ _____

Exhibitor _____ Booth _____
 Address _____
 City _____ State _____ Zip _____
 Phone _____ Fax _____
 Email _____ Contact _____

Return Via Fax: 305-751-1298

EXPO

CONVENTION CONTRACTORS, INC.

57 NE 179TH STREET, MIAMI, FLORIDA 33162
TEL: 305/751-1234 FAX: 305/751-1298

STS RENTAL EXHIBITS

STS 100 10' Exhibit



Includes: Header w/ Company Name, 3 shelves and 3 arm lights

STS 101 10' Exhibit



Includes: Header w/ Company Name, Panel choice, (see order form) 1 cabinet, 1 shelf, 3 arm

STS 102 10' Exhibit



Includes: Header w/ Company Name, Panel choice (see order form), 3 cabinets, 3 shelves, 3 arm lights, 2 side rails

STS 103 10' Exhibit



Includes: Header w/ Company Name, Panel choice (see order form), 2 cabinets, 2 shelves, 2 arm lights, 2 side rails, 1 light box

STS 300 30' Exhibit

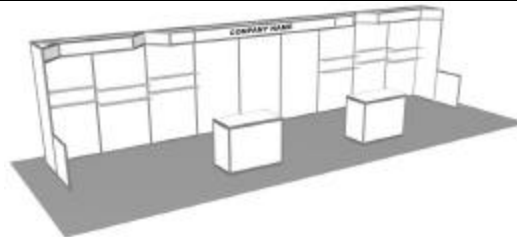

Includes: Header w/ Company Name, Panel choice (see order form), 12 shelves, 9 arm lights, 2 cabinets, 2 side rails

STS 200 20' Exhibit



Includes: 2 headers w/ Company Name, Panel choice (see order form), 6 shelves, 6 arm lights, 2 side rails

STS 201 20' Exhibit



Includes: Header w/ Company Name, Panel choice (see order form), 6 shelves, 6 arm lights, 2 cabinets, 2 side rails

STS 203 20' Exhibit

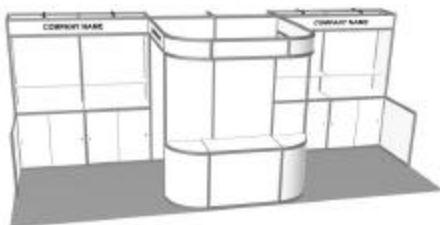

Includes: 5 headers w/ Company Name, Panel choice (see order form), 4 shelves, 6 arm lights, 4 cabinets, 1 curved cabinet, 2 side rails

STS 400 20'x20' Exhibit



Includes: 4 headers w/ Company Name, Panel choice including plexy glass (see order form), 4 shelves, 8 arm lights, 1 U-shaped custom counter

Call 305-751-1234 ext: 221 for details



CONVENTION CONTRACTORS, INC.
 57 NE 179TH STREET, MIAMI, FLORIDA 33162
 TEL: 305/751-1234 FAX : 305/751-1298

**THE INTERNATIONAL CONGRESS
 OF ESTHETICS & SPA
 ARLINGTON CONVENTION CENTER
 MARCH 22-23, 2009**

DEADLINE: MARCH 6, 2009

STS ACCESSORY ORDER FORM

WHITE CABINETS



39"l x 39"h x 18"d with sliding doors
 Advanced \$264.00 Floor \$335.50
 Quantity _____

SLAT WALL



Free standing 1m x 8 ft
 Advanced \$307 Floor \$395
 Quantity _____

LITERATURE RACK



Double Sided 1/2 m x 6 ft
 Advanced \$186 Floor \$230
 Quantity _____

GONDOLAS



Single Sided 2.4m x 1m
 Advanced \$306 Floor \$374
 Quantity _____
 Double Sided 2.4m x 1m
 Advanced \$383 Floor \$487
 Quantity _____

SHELVES

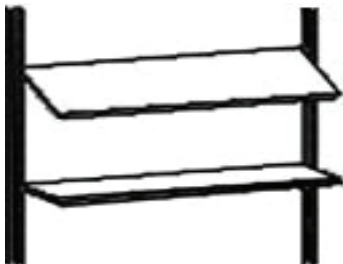

Additional white shelves and brackets
 Advanced \$32 Each Floor \$40 Each
 Quantity _____

GOOSE NECK LIGHTS



Spot Light 65 Watts
 Advanced \$50 Each Floor \$65 Each
 Quantity _____

**RETURN VIA FAX:
 305-751-1298**

SUB-TOTAL _____
 8.25% SALES TAX _____
 TOTAL _____

Exhibitor _____ Booth _____
 Address _____
 City _____ State _____ Zip _____
 Phone _____ Fax _____
 Email _____ Contact _____



CONVENTION CONTRACTORS, INC.
 57 NE 179TH STREET, MIAMI, FLORIDA 33162
 TEL: 305/751-1234 FAX : 305/751-1298

**THE INTERNATIONAL CONGRESS
 OF ESTHETICS & SPA
 ARLINGTON CONVENTION CENTER
 MARCH 22-23, 2009**

DEADLINE: MARCH 6, 2009

STS ACCESSORY ORDER FORM

ADJUSTABLE ARM RACK

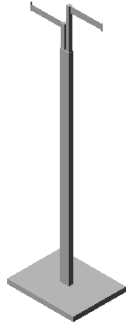

15" L, 55" H, 12" deep
 Advanced \$52.00
 Floor \$63.00
 Quantity _____

2-WAY WATER FALL RACK



15" L, 55" H, 18" deep
 Advanced \$66.00
 Floor \$83.00
 Quantity _____

4-WAY ARM RACK

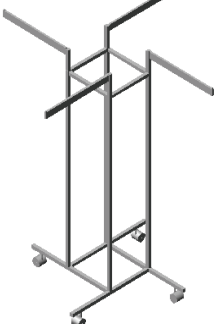

46.5" L, 54" H, 46.5" deep
 Advanced \$83.00
 Floor \$102.00
 Quantity _____

FREE-STANDING GRID

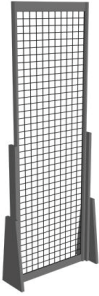

2' x 7'H
 Advanced \$93.00 Each
 Floor \$112.00 Each
 Quantity _____

SHOWCASE



½ mt L, ½ mt D, 6' H
 Advanced \$374.00
 Floor \$440.00
 Quantity _____

2 Meter Cabinet

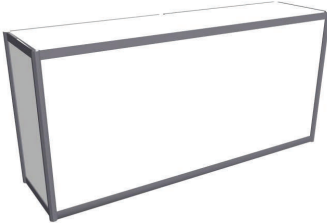

77" L, 39" h, 18" deep
 With sliding doors
 Advanced \$310.00
 Floor \$391.60
 Quantity _____

1 Meter Curved Counter



39" L, 39" H, 18" deep
 Advanced \$264.00
 Floor \$335.50
 Quantity _____

2 Meter Curved Counter

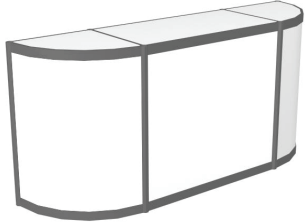

65"L, 39"H, 18" deep
 Advanced \$310.00
 Floor \$391.60
 Quantity _____

SUB-TOTAL ORDER _____
8.25% SALES TAX _____
TOTAL _____

<p>EXPO Convention Contractors, Inc. 57 N.E. 179th Street Miami, FLA. 33162 Tel: (305) 751-1234 Fax: (305) 751-1298</p>	FIRM NAME _____ BOOTH # _____
	ADDRESS _____
	CITY _____ STATE _____ ZIP _____
	TEL # _____ FAX # _____
	CONTACT NAME _____ EMAIL _____



CONVENTION CONTRACTORS, INC.
 57 NE 179TH STREET, MIAMI, FLORIDA 33162
 TEL: 305/751-1234 FAX: 305/751-1298

THE INTERNATIONAL CONGRESS
 OF ESTHETICS & SPA
 ARLINGTON CONVENTION CENTER
 MARCH 22-23, 2009

DEADLINE: MARCH 6, 2009

Custom Rental Exhibit Order Form SPACE TECH SYSTEM

PLEASE ENTER YOUR ORDER FOR RENTAL DISPLAY MODULE UNITS AS SPECIFIED BELOW.
 ALL ELECTRICAL AND UTILITY CHARGES WILL BE BILLED TO EXHIBITOR DIRECTLY BY ELECTRICAL CONTRACTOR.

Your Choice Hardwall Unit or Velcro Unit - STS 1200 - 2020 **ONLY**

Unit #	Advance Price	Standard Price	Please choose one of the following:	Carpet	TOTAL
STS 1100	\$3,025.00	\$3,782.00	White PVC Panel _____	Gray <input type="checkbox"/>	\$
STS 1200	\$3,245.00	\$4,057.00	Grey PVC Panel _____	Teal <input type="checkbox"/>	\$
STS 2000	\$5,225.00	\$6,532.00	Black PVC Panel _____	Blue <input type="checkbox"/>	\$
STS 2020	\$6,633.00	\$8,292.00	Blue PVC Panel _____	Burgundy <input type="checkbox"/>	\$
			Gray Velcro Panel _____	Black <input type="checkbox"/>	\$

**CANCELLATION POLICY: Items cancelled after move-in begins will be charged at 100%.
 Any custom panel or graphics cancelled after start of construction will be charged at 100%.**

(INSERT HEADER SIGN COPY IN BOX) BLACK HELVETICA LETTERS ARE STANDARD

We require _____ Rental Exhibits ***** @ \$ _____ = _____

We require the following accessories: Advance Standard

QUANTITY

_____ White cabinet (77" L. 30" H, 18" deep with sliding doors	@ \$234.00	\$301.00	= _____
_____ (Without STS Exhibit).....	@ \$282.00	\$356.00	= _____
_____ White cabinet 39" L, 39" H. 18" deep with sliding doors	@ \$192.00	\$246.00	= _____
_____ (without STS Exhibit)	@ \$240.00	\$305.00	= _____
_____ Side rail as shown (set of 2)	@ \$165.00	\$205.00	= _____
_____ Additional white shelves and brackets.....	@ \$ 32.00	\$ 40.00	= _____
_____ Velcro panel for STS Standard	@ \$125.00	\$155.00	= _____
_____ Pegboard Panel	@ \$125.00	\$155.00	= _____
_____ Slat-Wall Panel	@ \$225.00	\$280.00	= _____
_____ Special Color Panels	@ \$147.00	\$190.00	= _____
_____ Lock for Cabinets per cabinet.....	@ \$ 22.00	\$ 31.00	= _____

DUE TO PRE SHOW PREPARATIONS AND REQUIREMENTS Total all Items \$ _____
IT IS NECESSARY THAT ALL ORDERS FOR DISPLAY 8.25% Sales Tax \$ _____
MODULES BE ACCOMPANIED BY PAYMENT IN FULL Balance Due \$ _____
FOR ITEMS ORDERED 4 DAYS PRIOR TO MOVE-IN.

To qualify for discount prices, full payment must accompany the return of this order form and be received a minimum of four (4) days prior to move-in of event: Orders received without payment, placed at the show site or received after the twenty one (21) day cut off date will be at the standard rate in the event of cancellation, at charge of 50% of established price will be made. Settlement of ALL invoices are due prior to the close of that event. Please arrange to have your representative at the event prepared to settle all invoices of the time of ordering the specific service.

Exhibitor _____ Booth _____

Address _____

City _____ State _____ Zip _____

Phone _____ Fax _____

Email _____ Contact _____

CUSTOM RENTAL EXHIBIT

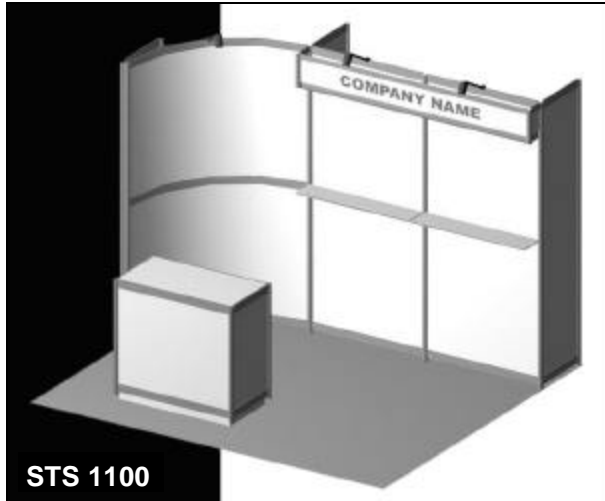

STS 1100

FEATURES

- Header with your company name
- 2 shelves
- 1 white cabinet
- 3 lights

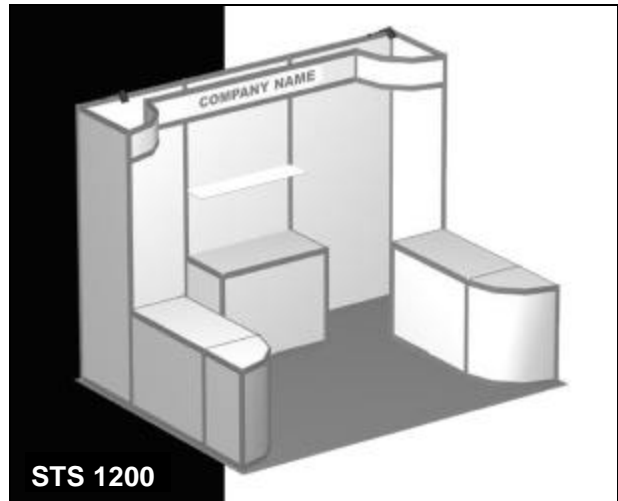

STS 1200

FEATURES

- Header with your company name
- 1 Shelf
- 1 white cabinet on back wall
- 2 side cabinets
- 2 lights

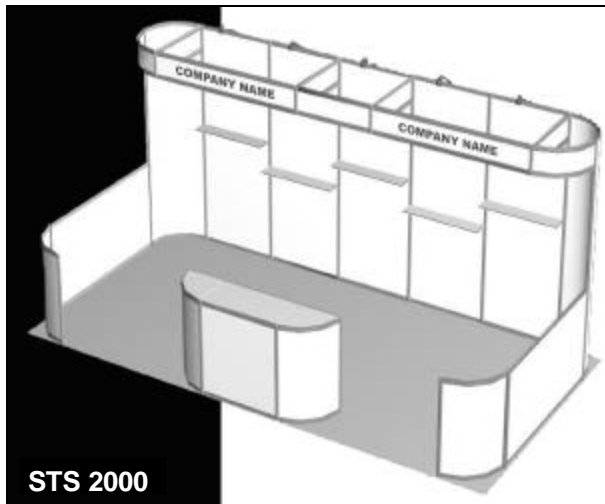

STS 2000

FEATURES

- 2 headers with your company name
- 5 spotlights
- 5 shelves
- 1 white cabinet
- 2 curved side rails

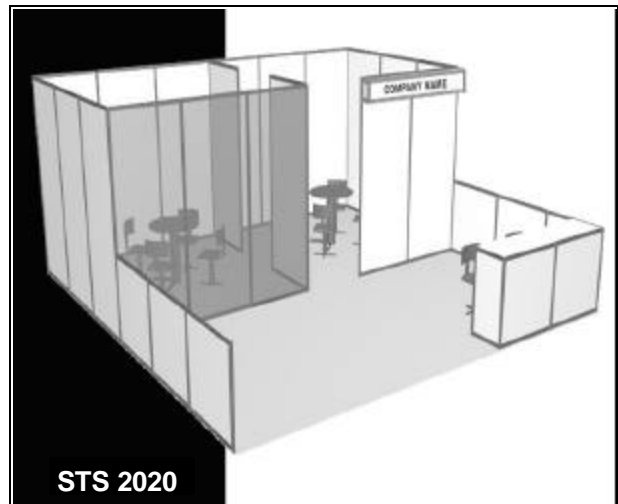

STS 2020

FEATURES

- Clear Plexi front on office
- 1 header with your company name
- 3 shelves
- 1 - 2 meter cabinet
- siderails





CONVENTION CONTRACTORS, INC.
 57 NE 179TH STREET, MIAMI, FLORIDA 33162
 TEL: 305/751-1234 FAX: 305/751-1298

**THE INTERNATIONAL CONGRESS
 OF ESTHETICS & SPA
 ARLINGTON CONVENTION CENTER
 MARCH 22-23, 2009**

Exhibit Shipping Information & Drayage Rate Schedule

Ship prepaid only. Collect shipments will be refused. Loose and uncrated materials will be received at Show-Site only. All charges are based on in-bound weights ONLY. Credit card must be provided.

ADVANCE SHIPMENT

Rates Include:

- Unloading crated material.
- Storing at EXPO's warehouse for up to 30 days.
- Unloading materials and delivery to your booth.
- Removing of empty shipping containers from your booth, storing and returning at close of show.
- Reloading materials onto outbound transportation.

SHOW-SITE SHIPMENT

(Will not be accepted prior to **MARCH 21, 2009**)

Rates Include:

- Unloading materials when received and delivery to your booth.
- Removal of empty shipping containers from your booth, storing and returning at close of show.
- Reloading materials onto outbound transportation.

Exhibitors should label and consign shipments as follows:

Company _____
 Booth Number _____
 Convention Name: **THE INTERNATIONAL CONGRESS
 OF ESTHETICS & SPA**

EXPO Convention Contractors, Inc.
 C/O UPS FREIGHT
 5001 David Strickland Road
 Fort Worth, TX 76119

Warehouse : \$59.00 per CWT.

With a 200 lb. minimum (CWT. = 100 lbs.)

Exhibitors should label and consign shipments as follows:

Company _____
 Booth Number _____
 Convention Name: **THE INTERNATIONAL CONGRESS
 OF ESTHETICS & SPA**

EXPO Convention Contractors, Inc.
 c/o ARLINGTON CONVENTION CENTER
 1200 Ballpark Drive East
 Arlington, TX 76011

Show-Site: \$55.00 per CWT.

With a 200 lb. minimum (CWT. = 100 lbs.)

_____ lbs. x \$59.00 per CWT. = \$ _____

_____ lbs. x \$55.00 per CWT. = \$ _____

ALL WAREHOUSE SHIPMENTS RECEIVED AFTER **MARCH 13, 2009** WILL BE CHARGED AN ADDITIONAL 25% FOR LATE HANDLING. Charges for these services are based on the inbound weight per shipment. Loose, uncrated, van line or pad wrapped shipments requiring special handling or improperly packaged materials will be assessed a 25% special handling fee. When move-in or move-out times are scheduled during overtime hours due to circumstances beyond EXPO's control, an additional 25% of regular rates is charged. Overtime hours are Monday through Friday before 8:00 am and after 4:30 pm, weekends and Holidays. EXPO is **not responsible** for any damage or loss of your freight. Please secure round trip insurance coverage from your company insurance carrier.

Exhibitor _____ Booth _____

Address _____

City _____ State _____ Zip _____

Phone _____ Fax _____

Email _____ Contact _____

SHIPPING INSTRUCTIONS AT CLOSE OF CONVENTION /TRADESHOW

Consign to : _____

Street Address : _____

City : _____ State : _____ Zip: _____

Type of Carrier: Motor Freight _____ Air _____ Van Line _____

If pre-paid bill to : _____

City, State and Zip : _____

ALL SHIPMENTS MUST ARRIVE PRE-PAID

1. Shipments must be consigned to EXPO Convention Contractors, Inc.. The hotel and convention site do not have the facilities to receive such shipments and they may be refused.
2. All shipments must be properly labeled and addressed to the warehouse or facility. It is understood that all shipments are released to Expo at a value not to exceed \$.30 per pound, per article. Exhibits left without return instructions will be returned to our warehouse and held for disposition at an additional charge, Expo is not responsible for condition, count or content until such time exhibits or materials are picked up for removal after the exhibition's close.
3. All materials should be properly insured against fire, theft and all hazards while in transit to and from your booth and for the exhibition's duration.
4. Exhibitor routing on outbound shipments is honored when possible. However, we reserve the right to reroute as necessary. All outbound shipments must be tendered with a Bill of Lading turned into the service desk at show site. In the event the designated carrier fails to pick up by a specified time, Expo Convention Contractors, Inc. will reroute said shipments.
5. All shipments requiring special handling for reasons including, but not limited to, length, width or height, are handled on a time and material basis.
6. Expo Convention Contractors, Inc., as the Official Drayage Contractor, has control over all freight docks, doors, elevators, and crate storage areas. A charge of \$25.00 per crate, box or carton is accessed for any shipment not handled by Expo Convention Contractors, Inc., when Expo is required to handle storage of empty containers.
7. Remove all expired shipping labels before shipping to avoid confusion.
8. Collect shipments are not accepted unless written authorization is furnished by shipper. There is a 25% surcharge (\$15.00 minimum) based on the amount advanced by Expo Convention Contractors, Inc.

EXPO CONVENTION CONTRACTORS, INC. WILL REROUTE ALL OUTBOUND SHIPMENTS UNLESS SPECIAL ARRANGEMENTS ARE MADE.

INSURANCE

Expo Convention Contractors, Inc. is not responsible for the count or content of material after it has been placed in the exhibit areas.

Exhibitor agrees to hold harmless Expo Convention Contractors, Inc. from responsibility for concealed and/or apparent damage to uncrated and or unskidded exhibit material.

Please make certain all materials are properly insured against "ALL RISK" while in transit to and from point of origin, to and from booth and for the exhibition's duration.

**AUTHORITY TO HANDLE & BILLING INSTRUCTIONS
ACCEPTANCE OF ALL ITEMS AND CONDITIONS HEREIN STATED:**

Company Name: _____

Address: _____

Attention: _____

City: _____ State: _____ Zip: _____

Authorized by (please print): _____ Title: _____

Signature: _____

Convention /Tradeshow: _____

To insure orderly processing of material handling requirements, it is absolutely essential that this form be READ, COMPLETED AND SIGNED by an organization officer and RETURNED PROMPTLY TO:

EXPO CONVENTION CONTRACTORS, INC. 57 NE 179 STREET, MIAMI, FLORIDA 33162, TEL: 305-751-1234



CONVENTION CONTRACTORS, INC.
57 NE 179TH STREET, MIAMI, FLORIDA 33162

FROM: Booth #: _____
Company Name: _____
Contact Name: _____
Address: _____
City, State, Zip: _____

TO: EXPO Convention Contractors, Inc.
C/O UPS FREIGHT
5001 David Strickland Road
Fort Worth, TX 76119

THE INTERNATIONAL CONGRESS OF ESTHETICS & SPA

ADVANCE SHIPMENT CONVENTION MATERIAL
Must Arrive No Later than March 13, 2009



CONVENTION CONTRACTORS, INC.
57 NE 179TH STREET, MIAMI, FLORIDA 33162

FROM: Booth #: _____
Company Name: _____
Contact Name: _____
Address: _____
City, State, Zip: _____

TO: EXPO Convention Contractors, Inc.
C/O UPS FREIGHT
5001 David Strickland Road
Fort Worth, TX 76119

THE INTERNATIONAL CONGRESS OF ESTHETICS & SPA

ADVANCE SHIPMENT CONVENTION MATERIAL
Must Arrive No Later than March 13, 2009



CONVENTION CONTRACTORS, INC.
57 NE 179TH STREET, MIAMI, FLORIDA 33162

FROM: Booth #: _____
Company Name: _____
Contact Name: _____
Address: _____
City, State, Zip: _____

TO: EXPO Convention Contractors, Inc.
C/O UPS FREIGHT
5001 David Strickland Road
Fort Worth, TX 76119

THE INTERNATIONAL CONGRESS OF ESTHETICS & SPA

ADVANCE SHIPMENT CONVENTION MATERIAL
Must Arrive No Later than March 13, 2009



CONVENTION CONTRACTORS, INC.
57 NE 179TH STREET, MIAMI, FLORIDA 33162

FROM: Booth #: _____
Company Name: _____
Contact Name: _____
Address: _____
City, State, Zip: _____

TO: EXPO Convention Contractors, Inc.
C/O UPS FREIGHT
5001 David Strickland Road
Fort Worth, TX 76119

THE INTERNATIONAL CONGRESS OF ESTHETICS & SPA

ADVANCE SHIPMENT CONVENTION MATERIAL
Must Arrive No Later than March 13, 2009



CONVENTION CONTRACTORS, INC.
57 NE 179TH STREET, MIAMI, FLORIDA 33162

FROM: Booth #: _____
Company Name: _____
Contact Name: _____
Address: _____
City, State, Zip: _____

TO:
EXPO Convention Contractors, Inc.
c/o Arlington Convention Center
1200 Ballpark Drive East
Arlington, TX 76011

THE INTERNATIONAL CONGRESS OF ESTHETICS & SPA
DIRECT SHIPMENT CONVENTION MATERIAL
Delivery on Saturday, March 21, 2009 Only



CONVENTION CONTRACTORS, INC.
57 NE 179TH STREET, MIAMI, FLORIDA 33162

FROM: Booth #: _____
Company Name: _____
Contact Name: _____
Address: _____
City, State, Zip: _____

TO:
EXPO Convention Contractors, Inc.
c/o Arlington Convention Center
1200 Ballpark Drive East
Arlington, TX 76011

THE INTERNATIONAL CONGRESS OF ESTHETICS & SPA
DIRECT SHIPMENT CONVENTION MATERIAL
Delivery on Saturday, March 21, 2009 Only



CONVENTION CONTRACTORS, INC.
57 NE 179TH STREET, MIAMI, FLORIDA 33162

FROM: Booth #: _____
Company Name: _____
Contact Name: _____
Address: _____
City, State, Zip: _____

TO:
EXPO Convention Contractors, Inc.
c/o Arlington Convention Center
1200 Ballpark Drive East
Arlington, TX 76011

THE INTERNATIONAL CONGRESS OF ESTHETICS & SPA
DIRECT SHIPMENT CONVENTION MATERIAL
Delivery on Saturday, March 21, 2009 Only



CONVENTION CONTRACTORS, INC.
57 NE 179TH STREET, MIAMI, FLORIDA 33162

FROM: Booth #: _____
Company Name: _____
Contact Name: _____
Address: _____
City, State, Zip: _____

TO:
EXPO Convention Contractors, Inc.
c/o Arlington Convention Center
1200 Ballpark Drive East
Arlington, TX 76011

THE INTERNATIONAL CONGRESS OF ESTHETICS & SPA
DIRECT SHIPMENT CONVENTION MATERIAL
Delivery on Saturday, March 21, 2009 Only



CONVENTION CONTRACTORS, INC.

57 NE 179TH STREET, MIAMI, FLORIDA 33162
TEL: 305/751-1234 FAX: 305/751-1298

THE INTERNATIONAL CONGRESS
OF ESTHETICS & SPA
ARLINGTON CONVENTION CENTER
MARCH 22-23, 2009

AREA WORK RULES

To assist you in planning for your participation in this event, we are certain you appreciate knowing in advance that union labor is required for certain aspects of your exhibit handling. To help you understand the Area Work Rules, we ask you to read the following:

FREIGHT HANDLING

The Local Union claims jurisdiction over the operation of all material handling equipment, all unloading and reloading. An exhibitor may move material that is hand-carriable by one person in one trip, without the use of dollies, hand truck or other mechanical equipment. When exhibitors choose to hand-carry in accordance with the foregoing, they are not permitted access to the loading dock area(s).

EXPO is responsible for receiving and handling all exhibit materials and empty crates. It is our responsibility to manage loading docks and schedule vehicles for the smooth and efficient move-in and move-out of the exposition.

DISPLAY

The Local Union claims jurisdiction over the erection, dismantling, repair and building of all exhibits. These exhibits can run from floor to ceiling and include headers, floor covering, aisle covering, hanging of decorating materials from ceilings, painting and hanging of all type of signs, pictorial and scenic paintings, etc.

GRATUITIES

We request that exhibitors do not tip (such practices as giving money, merchandise, or other special consideration for services rendered) employees. Do not give coffee breaks other than mid-morning and mid-afternoon, when union employees have fifteen minute paid breaks. Any attempts to solicit a gratuity by an employee for any service should be reported immediately to a supervisor. Employees are paid at an excellent wage. Tipping is strongly discouraged and is not an accepted company policy.

EXPO HOLD HARMLESS AGREEMENT / VEHICLE SPOTTING

The Association and Exhibitor will hold harmless EXPO Convention Contractors, Inc. for any damage or injury resulting from vehicle spotting. Damage or injury to Vehicle/Driver/3rd Party Personnel/Display.

IN GENERAL

Craftsmen at all levels are instructed to refrain from expressing any grievances or directly challenging the practices of any exhibitor. It is recommended that any questions arising with regard to union jurisdiction or practices be directed to an EXPO management representative.



CONVENTION CONTRACTORS, INC.
 57 NE 179TH STREET, MIAMI, FLORIDA 33162
 TEL: 305/751-1234 FAX: 305/751-1298

THE INTERNATIONAL CONGRESS
 OF ESTHETICS & SPA
 ARLINGTON CONVENTION CENTER
 MARCH 22-23, 2009

DEADLINE: MARCH 6, 2009

LABOR ORDER

	NO. MEN	DATE	TIME	APPROX. HRS
LABOR TO SET UP DISPLAY				
LABOR TO DISMANTLE DISPLAY				

STRAIGHT TIME LABOR: \$79.00 Hourly; Monday through Friday 8:00am to 4:30pm
OVERTIME LABOR: \$118.50 Hourly; Before 8:00am and after 4:30pm Monday Through Friday
DOUBLE TIME: \$158.00 Hourly; All Day Saturday, Sunday and Holidays

PLEASE INDICATE SERVICE DESIRED

SERVICE "A"

STARTING TIME CAN BE GUARANTEED ONLY WHEN MEN ARE REQUESTED FOR THE START OF THE WORK DAY.

Exhibitor's representative must check in at the Service Desk to pick up men ordered. Also, Exhibitor's representative must sign men in at the Service Desk upon completion of work to ensure proper billing for services. ALL WORK IS DONE UNDER THE SUPERVISION OF THE EXHIBITOR REPRESENTATIVE. Please indicate the name of your representative to pick up and supervise men:

Representative's Name _____

SERVICE "B"

All work is done under the supervision of Expo. The charge for this service is 40% of your total labor bill with, a \$50.00 minimum charge. This service saves the expense and loss of productive time of your personnel.

TO COMPLETE THE WORK WITHOUT YOUR REPRESENTATIVE PRESENT, PLEASE SUBMIT THE FOLLOWING INFORMATION:

- | | |
|--|--|
| <input type="checkbox"/> Self-contained unit | <input type="checkbox"/> Set-up plans attached |
| <input type="checkbox"/> No. of crates _____ | <input type="checkbox"/> Set-up Plans in crate # _____ |
| <input type="checkbox"/> Photo attached | <input type="checkbox"/> Special instructions attached |

Return To: EXPO Convention Contractors, Inc. 57 NE 179th Street Miami, Florida 33162 Tel: 305-751-1234 Fax: 305-751-1298	Exhibitor _____ Booth _____ Address _____ City _____ State _____ Zip _____ Phone _____ Fax _____
--	---



CONVENTION CONTRACTORS, INC.
 57 NE 179TH STREET, MIAMI, FLORIDA 33162
 TEL: 305/751-1234 FAX : 305/751-1298

THE INTERNATIONAL CONGRESS
 OF ESTHETICS & SPA
 ARLINGTON CONVENTION CENTER
 MARCH 22-23, 2009

DEADLINE: MARCH 6, 2009

NON-OFFICIAL CONTRACTOR REQUEST FORM

For Exhibitors intending to use its own labor or contract for such services separately from EXPO, please read the following restrictions, requirements, and restraints. A non-official service contractor is any company, other than the designated official contractors, that an exhibitor wishes to use that requires access to the exhibit hall either before, during or after the Show. Use of a non-official contractor who requires any of the following services is not permitted: electrical, plumbing, telephone lines, drayage, rigging, booth cleaning, and catering.

NOTE: A valid and current copy of Exhibitor's contractor's Certificate of Insurance naming EXPO Convention Contractors, Inc. must accompany this document. If these documents are not provided, Exhibitor will not be allowed to use contractor's services in the area where unions claim jurisdiction.

NOTE: Complete this form only if your company is using a Service Contractor other than the official decorating company to unpack, erect, assemble, dismantle or pack your display. **The local union claims jurisdiction over the erection, dismantling, repair and building of all exhibits.**

PLEASE COMPLETE:

_____ will indemnify and hold harmless EXPO Convention Contractors, Inc. from and against any bodily injury or property damage liability claims, judgments, damages, costs or expense, including reasonable attorney fees, arising out of or occasioned by the operations performed by _____ except for occurrences or accidents caused by the sole negligence of EXPO Convention Contractors, Inc., or for occurrences or accidents by any other party.

Exhibitor _____ Booth # _____

Address _____

City _____ State _____ Zip _____

Telephone _____ Fax: _____

Authorized on-site representative _____
 (Please Print) *****

Name of Service Firm _____

Address _____

City _____ State _____ Zip _____

Telephone _____ On-Site Supervisor _____

Return this form, along with Certificate of Insurance, and name and address of the employee/s who are working in your booth by **MARCH 6, 2009** to EXPO, the Official Decorating Contractor:

EXPO CONVENTION CONTRACTORS, INC.
 57 NE 179th Street, Miami, Florida 33162
 ATTN: EXHIBITOR SERVICES
 Tel: 305-751-1234 Fax: 305-751-1298
 nstewart@expocci.com



CONVENTION CONTRACTORS, INC.
 57 NE 179TH STREET, MIAMI, FLORIDA 33162
 TEL: 305/751-1234 FAX: 305/751-1298

THE INTERNATIONAL CONGRESS
 OF ESTHETICS & SPA
 ARLINGTON CONVENTION CENTER
 MARCH 22-23, 2009

DEADLINE: MARCH 6, 2009

CLEANING SERVICE

Please Complete and Fax to EXPO Immediately

Please indicate the Services Needed

Carpet Cleaning		Rate	Booth Size**	# Days	Total
<input type="checkbox"/> (Check if Needed)	Vacuuming	\$0.32 per sq. ft.	X _____ (# Sq. Feet)	X _____ (# Days Needed)	= \$ _____ Total Due
<input type="checkbox"/> (Check if Needed)	Shampoo	\$0.40 per sq. ft.	X _____ (# Sq. Feet)	X _____ (# Days Needed)	= \$ _____ Total Due

** All Rates Based on Gross Booth/Display Area, 100 square feet Minimum

Porter Service - Trash Removal (2 hour intervals)

<input type="checkbox"/> (Check if Needed)	1 - 5 Booths:	\$45.00 @ _____ (Number Intervals Per Day)	X _____ (Total Number Days)	= \$ _____ Total Due
<input type="checkbox"/> (Check if Needed)	6 -15 Booths:	\$55.00 @ _____ (Number Intervals Per Day)	X _____ (Total Number Days)	= \$ _____ Total Due
<input type="checkbox"/> (Check if Needed)	Exhibit cleaning & dusting of display daily	\$25.00	X _____ # of days	= \$ _____
<input type="checkbox"/> (Check if Needed)	Exhibit cleaning & dusting 1 time only	\$35.00	_____ \$ (Specify Date Needed)	_____

Please Specify Dates Needed for Services: _____

Total Order _____

8.25% Sales Tax _____

Total Due _____

RETURN VIA FAX: 305-751-1298

Exhibitor _____ Booth _____

Address _____

City _____ State _____ Zip _____

Phone _____ Fax _____

Email _____ Contact _____



CONVENTION CONTRACTORS, INC.
 57 NE 179TH STREET, MIAMI, FLORIDA 33162
 TEL: 305/751-1234 FAX: 305/751-1298

**THE INTERNATIONAL CONGRESS
 OF ESTHETICS & SPA
 ARLINGTON CONVENTION CENTER
 MARCH 22-23, 2009**

DEADLINE: MARCH 6, 2009

SIGN AND DISPLAY CARD ORDER FORM

Please provide the following information:

- A. Size
- B. Exact copy, as you wish it to appear
- C. Color or colors for copy and show card
- D. Indicate vertical or horizontal
- E. Easel back, if desired
- F. Maximum 3 full lines of copy, additional charge for extra copy

**RETURN VIA FAX:
 305-751-1298**

PRICES ARE FOR BLACK COPY ON WHITE SHOW CARD

Advance Orders	Late Orders	Size	Qty.	Horizontal	Vertical	Color	Easel Back
42.00	66.00	9" x 44"					
43.00	67.00	11" x 14"					
53.00	93.00	14" x 22"					
75.00	119.00	22" x 28"					
97.00	182.00	28" x 44"					
185.00	292.00	40" x 60"					

SIGN COPY AS FOLLOWS:

1. Please add 8.25% Sales Tax to all orders; Over 10 words, add \$1.10 per word.
2. Additional charges for reproduction of emblem, logo, trademark, etc., are determined upon receipt of order. Colored show card and each change of color in copy will also receive an additional charge. Advance quote provided upon special request.
3. For easel back applied to sign, please add \$5.75
4. Signs ordered less than 72 hours prior to show opening will be billed at double the late order charge.

Exhibitor _____ Booth _____

Address _____

City _____ State _____ Zip _____

Phone _____ Fax _____

Email _____ Contact _____



SERVICE ORDER FORM

MAIL TO: Arlington Convention Center, 1200 Ballpark Way, Arlington, Texas 76011
Phone (817) 459-5006; Fax (817) 459-5091; brenda.gardner@arlingtontx.gov



PLEASE PRINT OR TYPE: Payment In Full Must Be Rendered Before Service Is Connected.

NAME OF EVENT _____ BOOTH NO. _____
 EXHIBIT NAME _____ PHONE NO. _____
 ADDRESS _____ CITY _____ STATE _____ ZIP _____
 AUTHORIZED PERSON _____ TITLE _____
 AUTHORIZED SIGNATURE _____ EVENT DATE _____

PAYMENT INFORMATION: Enclosed is my check or money order in the amount of \$ _____ Check # _____
 Visa MasterCard AMEX Discover Diners Club **Make check payable to Arlington Convention Center**
 Credit Card Acct. No. _____ Exp. Date _____ CVV2 Code _____
 Name (please print) _____ Authorized Signature _____
 Card Billing Address _____ City _____ State _____ Zip _____

ELECTRICAL SERVICE CONNECTIONS: Deadline to preorder – one week prior to show

QUANTITY	DESCRIPTION	ADVANCE ORDER & PAYMENT	FLOOR ORDER	AMOUNT
_____	20 Amps / 120V 1Ø (duplex plug) (EXHIBIT HALL)	\$50.00	\$60.00	\$ _____
_____	500 Watts (duplex plug) (GRAND HALL)	\$50.00	\$60.00	\$ _____

QUANTITY	DESCRIPTION	Load KW	VOLTAGE	PHASE 1ØA 3ØA	NEUTRAL REQ.?	ADVANCE ORDER & PAYMENT	FLOOR ORDER	AMOUNT
_____	6KW.....	_____	208	29 17	_____	\$140.00	\$160.00	\$ _____
_____	10KW.....	_____	208	48 28	_____	\$175.00	\$200.00	\$ _____
_____	20KW.....	_____	208	96 56	_____	\$225.00	\$250.00	\$ _____
_____	35KW.....	_____	208	N/A 97	_____	\$250.00	\$275.00	\$ _____

Service of 100 AMPS and greater not available in all locations. Additional cost to bring service to those areas will be charged.
 480V – Limited Locations – call for pricing
 Internal electrical connections will be charged labor at \$40/hr. (minimum 1/2 hour) \$ _____

 _____ 20' Extension Cord AND/OR Multi Outlet Assembly - (CIRCLE) Does Not Include Connection \$15.00 ea. \$ _____

COMPRESSED AIR, WATER & DRAIN (Available in EXHIBIT HALL only)

QUANTITY	DESCRIPTION	ADVANCE ORDER & PAYMENT	FLOOR ORDER	AMOUNT
_____	Initial Service Connection(s).....	\$125.00	\$250.00	\$ _____
_____	Each Additional Service Connection(s).....	\$ 25.00	\$ 40.00	\$ _____
_____	Equipment CFM _____ *Exhibitors must furnish necessary filter driers, regulators and fittings to connect to 1/4" Milton Quick Connect.			

Water Connections: 55-65 P.S.I. (Service Outlet 3/4" hose/faucet connection/FPT)** Deadline to preorder: One week prior to show.

_____	Initial Service Connection(s).....	\$ 75.00	\$150.00	\$ _____
_____	Each Additional Service Connection(s).....	\$ 20.00	\$ 30.00	\$ _____

Drainage Connections: Deadline to preorder: One week prior to show.

_____	Each Service Connection.....	\$ 50.00	\$ 125.00	\$ _____
-------	------------------------------	----------	-----------	----------

One Time Fill & Drain (500 gallon max): Deadline to preorder: One week prior to show.

_____	Up to 500 gallons.....	\$125.00	\$150.00	\$ _____
-------	------------------------	----------	----------	----------

Air and water service available to most locations. Contact ACC for location availability. If not available from adjacent floor box, additional cost to bring service to booth will be charged.

** Exhibitors must furnish necessary regulators and male pipe thread for connection.

Service will be brought to the rear of the booth in the most convenient manner.
Any variation from that will be on a time and material basis.

RULES AND REGULATIONS ON BACK

Order Serviced By: _____

White-ACC Billing Copy; Yellow-ACC Engineer's Copy;
Pink-ACC Fiscal File; Goldenrod-Customer Copy

TOTAL	\$ _____
*LESS PAYMENTS	\$ _____
BALANCE DUE	\$ _____
* Payment must accompany order to receive advance rates. (Sales tax is reflected in all prices shown.)	

RULES AND REGULATIONS

1. All equipment must comply with the National Electrical Code, all Federal, State, and local Safety Codes.
2. Claims will not be considered unless filed by exhibitor prior to close of show.
3. All material and equipment furnished by the Convention Center for this service order shall remain the property of the Convention Center and shall be removed ONLY by the Convention Center at the close of the show.
4. Unless otherwise directed, Convention Center personnel are authorized to cut floor coverings to permit installation of service.
5. The Convention Center reserves the right to refuse connection to any exhibitor whose equipment is deemed unsafe by Convention Center's electrical or plumbing supervisors.
6. RATES QUOTED FOR ALL CONNECTIONS COVER ONLY ONE SERVICE INSTALLATION TO THE BOOTH IN THE MOST CONVENIENT MANNER, AND DOES NOT INCLUDE CONNECTION ANY EXHIBITOR EQUIPMENT OR WIRING.
7. ADVANCE ORDERS: TO RECEIVE ADVANCE RATE, ADVANCE ORDERS MUST BE RECEIVED A MINIMUM OF FIVE (5) DAYS PRIOR TO EXHIBITORS' ARRIVAL FOR MOVE-IN AND PAYMENT MUST ACCOMPANY ORDER.
8. CREDIT WILL NOT BE GIVEN FOR OUTLETS INSTALLED AND NOT USED.
9. PAYMENT IN FULL MUST BE RENDERED PRIOR TO SERVICE CONNECTION.
10. Advance orders shall receive priority service.
11. Prices are based upon current wage rates and are subject to change without notice.
12. OBSTRUCTIONS BLOCKING UTILITY ACCESS FROM FLOOR BOXES OR WALL PANELS ARE SUBJECT TO RELOCATION AS NECESSARY.

ADDITIONAL RULES AND REGULATIONS – ELECTRICAL ONLY

1. Use of open clip sockets, latex or lamp cord wire, unapproved duplex or triplex attachment plugs in exhibits is prohibited.
2. Permanent building electrical outlets are not a part of booth space and are not to be used by exhibitors unless specified otherwise.
3. Under NO circumstances shall anyone other than "house electrician" make electrical connections.
4. Special equipment requiring company engineers or technicians for assembly, servicing, preparatory work, and operation may be executed without "house electrician," however, all services connections and overload protection to such equipment must be made by "house electrician" only.
5. All equipment must be properly tagged or marked with complete information as to the type and/or amount of current, voltage, phase, frequency, horsepower, etc., required.
6. All exhibitors' 120 VOLT cords must be of the 3 wire, grounded type. All exposed non-current carrying metal parts of fixed equipment, which are liable to be energized, shall be grounded.

ADDITIONAL RULES AND REGULATIONS – AIR/WATER/DRAIN ONLY

1. Air and water service pressure may vary and no guarantee can be made of minimum or maximum pressures. If pressure is critical, exhibitor should arrange to have a pressure regulator valve installed.
2. ADDITIONAL LABOR CHARGES MAY BE MADE FOR EXHIBITORS' EQUIPMENT THAT SHOULD LEAK OR CAUSE DAMAGE TO OTHER PROPERTY.



INTERNET & TELEPHONE SERVICE ORDER FORM

Arlington Convention Center • 1200 Ballpark Way, Arlington, Texas 76011
Phone (817) 459-5006 • Fax (817) 459-5091 • brenda.gardner@arlingtontx.gov



PLEASE READ BEFORE COMPLETING THIS FORM: While you may prefer to pay for services with a check or cash, the Arlington Convention Center additionally requires that you complete the credit card information below. This will assure that the Center is guaranteed payment for your local and/or long distance charges. If you feel you need further clarification of this policy, please call our Exhibitor Services at (817) 459-5006.

PLEASE PRINT OR TYPE: Payments in Full Must Be Rendered Before Service is Connected.

Name of Event _____ Booth No. _____
 Exhibitor Name _____ Phone No. _____
 Mailing Address _____ City _____ State _____ Zip _____
 Authorized Signature _____ Event Date _____

PAYMENT INFORMATION: Enclosed is my check or money order in the amount of \$ _____ Check # _____
 Visa MasterCard AMEX Discover Diners Club **Make check payable to Arlington Convention Center**
 Credit Card Acct. No. _____ Exp. Date _____ CVV2 code _____
 Name (please print) _____ Authorized Signature _____
 Card Billing Address _____ City _____ State _____ Zip _____

QUANTITY	SERVICE	RATE	AMOUNT
_____	Standard Exhibitor Telephone Line with Touch Tone Instrument	\$ 95.00	\$ _____
_____	Standard Exhibitor Line (Exhibitor uses own instrument)	\$ 95.00	\$ _____
_____	Standard Exhibitor Telephone Line with Touch Tone Speaker instrument	\$135.00	\$ _____
_____	If toll restriction is desired, please add service charge	\$ 10.00	\$ _____
_____	DSL Ethernet Connection (limited quantity)	\$325.00	\$ _____
_____	High-Speed Wireless Internet	\$325.00	\$ _____

RULES AND REGULATIONS

- IT IS THE EXHIBITOR'S RESPONSIBILITY TO ENSURE THAT CREDIT CARD MACHINES AND COMPUTERS ARE PROGRAMMED FOR DIAL 9 CALLING. CONTACT YOUR CREDIT CARD PROCESSOR FOR ALL CREDIT CARD PROGRAMMING INSTRUCTIONS.**
- Cables from modem to computer are not supplied by the Convention Center.
- PC's must be configured to allow set up for internet connection.
- In addition to basic telephone charge, exhibitor will be charged for local and long distance calls at the prevailing rates.
- A final summary statement detailing calls and charges, including taxes, will be sent to addressee listed on this form.
- Claims will not be considered unless filed by exhibitor prior to close of show.
- All material and equipment furnished by the Convention Center for this service order shall remain the property of the Convention Center.
- Unless otherwise directed, Convention Center personnel are authorized to cut floor coverings to permit installation of service.
- Credit will not be given for telephones installed and not used.
- Prices are based upon current wage rates and are subject to change without notice.
- Obstructions blocking utility floor boxes are subject to relocation as necessary.

TOTAL	\$ _____
LESS PAYMENT	\$ _____
BALANCE DUE	\$ _____
(Sales tax is reflected in all prices shown.)	

DISCLAIMER:

All users of this service agree to hold the City of Arlington, TX (hereafter referred to as City) or the Arlington Convention Center and its agencies harmless from any and all claims, losses, damages, obligations or liabilities, directly or indirectly relating to this service. In no event shall the City or the Arlington Convention Center and its agencies have any liability for lost profits or for indirect, special, punitive, or consequential damages or any liability to any third party, even if the City or the Arlington Convention Center and its agencies are advised of the possibility of such damages.

USER EXPRESSLY AGREES THAT USE OF THE SERVICE IS AT USER'S SOLE RISK THAT THE SERVICE IS PROVIDED ON AN "AS IS" BASIS.

Audio Visual Exhibitor Form



1200 Ballpark Way • Arlington, Texas 76011

Phone: (817)459-5017

Fax: (817)303-6048 • E-Mail :johna@jsav.com •

WWW.JSAV.COM

VIDEO PLAYERS

	QTY	Advance Daily Rental	After Deadline Daily Rental	Total
1/2" VHS Video Cassette Player with Auto Repeat	_____	65.00	75.00	_____
1/2" PAL/SEACAM/NTSC Player	_____	125.00	145.00	_____
DVD Player	_____	85.00	95.00	_____
Beta SP Player / Recorder	_____	350.00	395.00	_____

VIDEO MONITOR/RECEIVER

19-20" Color Monitor/Receiver	_____	60.00	69.00	_____
20" PAL / SEACAM / NTSC Monitor	_____	100.00	115.00	_____
26-27" Color Monitor (Specify)	_____	75.00	86.00	_____
32" Monitor/Receiver	_____	175.00	201.00	_____
42" Plasma Monitor With Stand	_____	450.00	495.00	_____

1/2" VHS VIDEO PLAYER/MONITOR COMBINED

19" Monitor / Player Combination	_____	110.00	126.50	_____
27" Monitor / Player Combination	_____	150.00	165.00	_____

VIDEO ENHANCEMENT

Camcorder with Tripod	_____	100.00	115.00	_____
3 Chip Camera With Tripod	_____	400.00	450.00	_____
Navitar Slide to Video Transfer	_____	125.00	145.00	_____

PROJECTION

Overhead Projector	_____	40.00	48.00	_____
Super Bright Overhead Projector (4000 Lumen)	_____	50.00	58.00	_____
Kodak 35mm Slide Projector	_____	25.00	29.00	_____
Caramate 35mm Projector with Built-in 12" Screen	_____	40.00	46.00	_____
Tripod Screens up to 96"	_____	30.00	35.00	_____

COMPUTER DATA DISPLAY

1000 Lumen LCD Projector	_____	250.00	285.00	_____
2200 Lumen LCD Projector	_____	350.00	385.00	_____
3300 Lumen LCD Projector	_____	500.00	585.00	_____
20" LCD Computer Monitor	_____	150.00	170.00	_____
32" LCD Monitor	_____	275.00	350.00	_____
42" Plasma Monitor With Stand	_____	450.00	495.00	_____
50" Plasma Monitor With Stand	_____	550.00	600.00	_____

Orders received prior towill be charged the Advance Daily Rental Rate.

AUDIO

	QTY	Advance Daily Rental	After Deadline Daily Rental	Total
Portable System: 2 Self-Amplified Speakers, 2 Stands, 4 Channel Mixer, XLR Breakout Box	_____	\$125.00	\$145.00	_____
200 Watt System: 2 EV Speakers, 2 Stands, 1-8 Channel Mixer	_____	150.00	175.00	_____
4 Channel Mixer	_____	30.00	35.00	_____
8 Channel Mixer	_____	60.00	69.00	_____
Microphone: Hand, Lapel (Specify by Circling)	_____	25.00	29.00	_____
Wireless Microphone: Hand, Lapel, Headset (Specify by Circling)	_____	125.00	135.00	_____
CD Player	_____	35.00	40.00	_____
Stereo Cassette Player/Recorder	_____	35.00	40.00	_____
Self Amplified Speaker	_____	50.00	58.00	_____

MISCELLANEOUS EQUIPMENT

Monitor Cart with Drape	_____	20.00	25.00	_____
Sizes: 34" 42" 54" (Specify by Circling)	_____	15.00	20.00	_____
Projection Stand	_____	35.00	40.00	_____
Laser Pointer	_____	25.00	30.00	_____
Flip Chart with Marker	_____			_____

CALCULATING YOUR ORDER

INSTRUCTIONS:

1. Add Quantity of Items by Applicable Daily Rental and Insert Here (1) _____
2. Multiply Total of #1 by _____ Show Days (2) _____
3. Add Delivery, 30 Minute Set-up, and Pick-up Fee (3) 50.00
4. Additional Labor (See Reverse Side.) (4) _____
5. Calculate Tax 8.00% (5) _____

Total Charges: _____

- **ALL PAYMENTS MUST BE MADE IN ADVANCE IN U.S. FUND**
- **SIGN IN THE SPACE BELOW SO THAT YOUR ORDER MAY BE PROCESSED.**

EXHIBITOR INFORMATION

Company Name _____ Booth # _____

Address _____

City _____ State _____ Zip _____

Phone _____ Fax _____

On Site Contact _____ Signature _____

If Delivery Date Differs From Actual
Show Dates Please Indicate HereDelivery Date _____ Delivery Time _____
Pickup Date _____ Pickup Time _____

Please fax all orders to (817)303.6048

If you have any questions about your order please call:
John Anderson 817-459-5017

PAYMENT INFORMATION

Cash Company Check (Payable to J & S Audio Visual)

Visa MasterCard American Express Diners Club

Company / Cardholder's Name _____

Cardholder Billing Address _____

City _____ State _____ Zip _____ Phone# _____

Are you the cardholder? () Yes () No Is this a Corporate Card? () Yes () No

If yes, what is the Corporate Code Number - 4 Digit number: _____

This card will be used to pay for charges by the following authorized users: (Please Print Clearly)

(1) _____ (2) _____

Credit Card # _____ Exp. Date _____

Signature _____ Date _____

INSURANCE EXHIBITOR - REQUIRED

ALL EXHIBITORS MUST PROVIDE A CERTIFICATE OF INSURANCE FOR THE EVENT BEFORE THEY ARE PERMITTED ONTO THE FLOOR.

Insurance Requirements per your contract:

Limit of Insurance: \$1,000,000
Type of Insurance: General Liability
Dates of Coverage: 03/21/09 to 03/25/09

Additional Insured Clause:

Aesthetic Expo - Dallas
c/o Show Insurance, Inc.
29100 Aurora Road, #100
Solon, OH 44139

Please choose one of the options below to complete your requirement:

OPTION 1 – COMPLETE USING SHOW INSURANCE

Complete your requirement in less than 3 minutes using Show Insurance. We will provide the general liability, notify Aesthetic Congress Communications and send you a confirmation that the requirement has been completed.

	Mail / Fax	Online	
Pay by 02/20/09	\$90	\$80	ONLINE – go to www.showinsurance.com
Pay after 02/20/09	\$110	\$100	MAIL/FAX – Complete the fax form on the
Pay after 03/06/09	\$150	\$140	next page.

To register and pay online please go to www.showinsurance.com.

OPTION 2 – COMPLETE USING YOUR OWN PROVIDER

1. Contact your insurance provider to get a certificate of insurance.
2. Make sure the certificate of insurance names the certificate holder above as an additional insured.
3. Please fax, mail or email one certificate of insurance to the address or number below.
4. After we review the certificate of insurance, we will send you notification that the requirement is completed. You must provide a certificate by **February 20, 2009!**

Email To: line@showinsurance.com

Mail To: Show Insurance, Inc.
c/o Aesthetic Expo - Dallas
29100 Aurora Road, #100
Solon, OH 44139

Fax To: 440-815-2154

Please discuss the cost with your provider for this service. Show Insurance will not charge any fee for this option.

Aesthetic Expo - Dallas has asked Show Insurance to handle all insurance issues for the International Congress of Esthetics – Dallas 2008 including collecting and verifying certificates of insurance. For further questions please visit our website at www.showinsurance.com.

Show Insurance, Inc. • 29100 Aurora Road • Suite 100 • Solon, OH • 44139
• P 440.349.6650 • F 440.815.2154 • www.showinsurance.com

ACORD CERTIFICATE OF LIABILITY INSURANCE

CSR
DECOR-1

DATE (MM/DD/YYYY)
10/04/06

PRODUCER Insurance Diversified Agency 29100 Aurora Road #100 Solon OH 44139 Phone: 440-349-5700 Fax: 440-349-5704	THIS CERTIFICATE IS ISSUED AS A MATTER OF INFORMATION ONLY AND CONFERS NO RIGHTS UPON THE CERTIFICATE HOLDER. THIS CERTIFICATE DOES NOT AMEND, EXTEND OR ALTER THE COVERAGE AFFORDED BY THE POLICIES BELOW.	
	INSURERS AFFORDING COVERAGE	NAIC #
INSURED Your Company Name Here	INSURER A:	Your Insurance Company
	INSURER B:	
	INSURER C:	
	INSURER D:	
	INSURER E:	

COVERAGES

THE POLICIES OF INSURANCE LISTED BELOW HAVE BEEN ISSUED TO THE INSURED NAMED ABOVE FOR THE POLICY PERIOD INDICATED. NOTWITHSTANDING ANY REQUIREMENT, TERM OR CONDITION OF ANY CONTRACT OR OTHER DOCUMENT WITH RESPECT TO WHICH THIS CERTIFICATE MAY BE ISSUED OR MAY PERTAIN, THE INSURANCE AFFORDED BY THE POLICIES DESCRIBED HEREIN IS SUBJECT TO ALL THE TERMS, EXCLUSIONS AND CONDITIONS OF SUCH POLICIES. AGGREGATE LIMITS SHOWN MAY HAVE BEEN REDUCED BY PAID CLAIMS.

INSR LTR	ADD'L INSRD	TYPE OF INSURANCE	POLICY NUMBER	POLICY EFFECTIVE DATE (MM/DD/YY)	POLICY EXPIRATION DATE (MM/DD/YY)	LIMITS
A		GENERAL LIABILITY <input checked="" type="checkbox"/> COMMERCIAL GENERAL LIABILITY <input type="checkbox"/> CLAIMS MADE <input checked="" type="checkbox"/> OCCUR GEN'L AGGREGATE LIMIT APPLIES PER: <input type="checkbox"/> POLICY <input type="checkbox"/> PRO-JECT <input type="checkbox"/> LOC	POLICY NUMBER	03/21/09	03/25/09	EACH OCCURRENCE \$ 1000000 DAMAGE TO RENTED PREMISES (Ea occurrence) \$ 100000 MED EXP (Any one person) \$ 5000 PERSONAL & ADV INJURY \$ 1000000 GENERAL AGGREGATE \$ 2000000 PRODUCTS - COMP/OP AGG \$ 2000000
		AUTOMOBILE LIABILITY <input type="checkbox"/> ANY AUTO <input type="checkbox"/> ALL OWNED AUTOS <input type="checkbox"/> SCHEDULED AUTOS <input type="checkbox"/> HIRED AUTOS <input type="checkbox"/> NON-OWNED AUTOS				COMBINED SINGLE LIMIT (Ea accident) \$ BODILY INJURY (Per person) \$ BODILY INJURY (Per accident) \$ PROPERTY DAMAGE (Per accident) \$
		GARAGE LIABILITY <input type="checkbox"/> ANY AUTO				AUTO ONLY - EA ACCIDENT \$ OTHER THAN AUTO ONLY: EA ACC \$ AGG \$
		EXCESS/UMBRELLA LIABILITY <input type="checkbox"/> OCCUR <input type="checkbox"/> CLAIMS MADE DEDUCTIBLE RETENTION \$				EACH OCCURRENCE \$ AGGREGATE \$ \$ \$ \$
		WORKERS COMPENSATION AND EMPLOYERS' LIABILITY ANY PROPRIETOR/PARTNER/EXECUTIVE OFFICER/MEMBER EXCLUDED? If yes, describe under SPECIAL PROVISIONS below				WC STATUTORY LIMITS OTH-ER E.L. EACH ACCIDENT \$ E.L. DISEASE - EA EMPLOYEE \$ E.L. DISEASE - POLICY LIMIT \$
		OTHER				

DRAFT

DRAFT

DESCRIPTION OF OPERATIONS / LOCATIONS / VEHICLES / EXCLUSIONS ADDED BY ENDORSEMENT / SPECIAL PROVISIONS

With respects to International Congress of Esthetics, Aesthetic Expo - Dallas, is named as an additional insured.

CERTIFICATE HOLDER Aesthetic Expo - Dallas c/o Show Insurance 29100 Aurora Road, Suite 100 Solon, OH 44139	QUEST - 1	CANCELLATION SHOULD ANY OF THE ABOVE DESCRIBED POLICIES BE CANCELLED BEFORE THE EXPIRATION DATE THEREOF, THE ISSUING INSURER WILL ENDEAVOR TO MAIL 30 DAYS WRITTEN NOTICE TO THE CERTIFICATE HOLDER NAMED TO THE LEFT, BUT FAILURE TO DO SO SHALL IMPOSE NO OBLIGATION OR LIABILITY OF ANY KIND UPON THE INSURER, ITS AGENTS OR REPRESENTATIVES. AUTHORIZED REPRESENTATIVE Andrew J Carson, CIC
---	------------------	---

Sales Lead Retrieval

Electronic Data Capture Terminal



This system gives exhibitors an immediate hard copy of the sales lead.

The sales lead will be sent to you by email immediately after the show. The file is in Excel format.

*saving inputting labor,
avoiding errors
and lost sales.*

Small footprint (10.5"x7.0"x3.12") and uses only 17 watts of electricity or optional battery pack.

**Exhibitors love
this dual system
to track their
hot sales**

This is an actual hard copy printout from the scanner.

Record: 132
Name FRANK KAPZYNSKI
Title PRESIDENT
Company TORCHIDS UNLIMITED
Street XXX STAMEN WAY
City BEDFORD NY 1XXX3
Phone XXX-XXX-XXXX
Fax XXX-XXX-XXXX
Email fkapzynsky@trochdis.com
Card * 2856
Entered 05-08-01 14:10:28

Answer:
Send Line Card
Set up Demo
Final Say

Record: 133
Name Qi Zhu
Title Vice President
Company CompuTec, Inc.
Street 5884 Cottonwood Dr.
City Ypsilanti, MI 48197
Country USA
Phone 734-572-4705
Fax 734-572-4715
Email qizhu@computec-inc.com
Card No. 7823
ENTERED 05-08-01 14:10:32

Answer:
Have Salesman Call
Immediate Need
End User
Recommends

ALL THE XXXs HAVE BEEN PUT IN TO PROTECT THE ATTENDEE.

Lead Qualifier Sheet

In addition to the demographic questions on the attendee registration form, this lead retrieving system comes with fifteen built-in qualifier questions. They are as follows:

- | | | |
|------------------------|-------------------|---------------------|
| 1. Send Line Card | 6. Provide Quote | 11. VAR |
| 2. Send Catalog | 7. Immediate Need | 12. OEM |
| 3. Send Detailed Quote | 8. Set up Demo | 13. Does Purchasing |
| 4. Send Sample | 9. End User | 14. Recommends |
| 5. Have Salesman Call | 10. Distributor | 15. Final Say |

This list could be customized to fit your individual needs. Please fill the following lines with the desired qualified questions and send with the order form on the front page. **Please print clearly!** There is no limitation on how many questions to be used, however, we recommend to limiting the number of questions to under 30.

[] Replace the build-in list

[] Add to the build-in list

1. _____
2. _____
3. _____
4. _____
5. _____
6. _____
7. _____
8. _____
9. _____
10. _____
11. _____
12. _____
13. _____
14. _____
15. _____
16. _____
17. _____
18. _____
19. _____

20. _____
21. _____
22. _____
23. _____
24. _____
25. _____
26. _____
27. _____
28. _____
29. _____
30. _____
31. _____
32. _____
33. _____
34. _____
35. _____
36. _____
37. _____
38. _____

Electronic Data
Capture Terminal



International Congress of Esthetics

Dallas, TX March 22 – 23, 2009

SALES TRACKING SCANNING SYSTEM

Gives you a hard copy of each \$ales lead.

Puts your \$ales lead info on your disc for later use.

\$aves you hundreds of dollars in data entry labor.

\$aves you hours of time.

Avoids costly error\$ for \$269.00 complete

The \$ALES TRACKING SYSTEM employs the latest scanning and software technology. Your \$ales leads are placed on the provided disk and can be transferred to most software systems as an ASCII file. Each disk can hold up to 4000 records and each roll of paper can print up to 400 records.

Description	Quantity	Advance Price*	Regular Price	Subtotal
Sales Tracking System		\$269.00	\$299.00	
Customized Lead Qualifier Sheet (See back side for details)		\$40.00	\$70.00	
* The advance date is March 1, 2009. No Refund after Sept 19, 2009			Total	

Name: _____ PH: _____ FX: _____ Booth _____

Company: _____ E-Mail: _____

Address: _____ City: _____ State: ___ ZIP: _____

Payment Method AMX MasterCard Visa Check payable to: **CompuTec Inc.**

Credit Card No. _____ Expiration _____

Cardholder Name: _____

Signature: _____ Date: _____

Send or Fax to: CompuTec Inc.

**5884 Cottonwood Dr.,
Ypsilanti, MI 48197**

**Ph: (734)572-4705
Fx: (734)572-4715**



The Lead Retrieval terminals are available for pickup on March, 2009 in registration area. The terminal should be returned to registration desk within one hour of the end of the show. Otherwise a charge of \$2400.00 will be applied to your company.

INTERNATIONAL CONGRESS OF ESTHETICS & SPA DALLAS 2009

March 22 & 23
Arlington Convention Center
Arlington, Texas

For Registration, Hotel Information and Reservations

Call Toll Free 1 (800) 471-0229 *Outside the U.S. call (305) 443-2322

Fax (305) 443-1664 or e-mail your request to REGISTRATION@LNEONLINE.COM

Visit our web site at: WWW.LNEONLINE.COM

Official Hotels for the Congress:

	<u>Single</u>	<u>Double</u>	<u>Triple</u>	<u>Quad</u>
Rates are Per Night				
Sheraton Arlington (formerly Wyndham Arlington) Superior First Class Located adjacent to Convention Center	\$122.00	\$122.00	\$127.00	\$127.00
Hilton Arlington First Class 1 mile from Convention Center	King Bed \$109.00	Two Double Beds \$119.00	N/A \$119.00	N/A \$119.00
Hawthorn Suites Arlington First Class 1 mile from Convention Center	\$99.00	\$99.00	\$99.00	\$99.00
	Rate Includes; Buffet Breakfast			
Baymont Inn & Suites Moderate First Class ¾ miles from Convention Center	\$69.00	\$69.00	\$69.00	\$69.00
	Rate Includes; Continental Breakfast			

- **All rates are PER NIGHT** – Plus 15% room tax.
Congress rates are subject to availability
- **CANCELLATION PENALTIES:**
- \$50.00 Cancellation fee if reservations are cancelled after March 6, 2009
- Full one night deposit if cancelled after March 13, 2009
- Cancellation Penalties are **STRICTLY ENFORCED**

Exhibitor Badge Form / Dallas 2009

In order to provide you with pre-printed name badges, it is important that you type or print clearly the names of each employee who will be working at the show in this form **and fax it back to us no later than Friday April February 27th, 2009.**

• **Fax number: 305-443-1664 - Attention Mayli Bueno.**

Badges should be worn at all times during the show and must be presented for daily admittance into the exhibition hall. The assigned badges/tickets are only for corporate exhibitors and their staffs and may not be used by customers, relatives or friends of show participants. Lost or stolen badges/ticket will not be replaced, but additional tickets may be purchased during the show at regular show price. Exhibitor badges will be assigned as follows;

One Booth	=	Four (4) Badges	Four Booths	=	Ten (10) Badges
Two Booths	=	Six (6) Badges	Five Booths	=	Twelve (12) Badges
Three Booths	=	Eight (8) Badges	Six Booths	=	Fourteen (14) Badges

Badges/tickets will be available for pick-up at the Exhibitor's booth located just outside the exhibition hall and proper I.D. plus a company business card are required for security verification

COMPANY NAME & BOOTH

	NAME	LAST NAME
1 ----	<input style="width: 100%; height: 20px;" type="text"/>	<input style="width: 100%; height: 20px;" type="text"/>
2 ----	<input style="width: 100%; height: 20px;" type="text"/>	<input style="width: 100%; height: 20px;" type="text"/>
3 ----	<input style="width: 100%; height: 20px;" type="text"/>	<input style="width: 100%; height: 20px;" type="text"/>
4 ----	<input style="width: 100%; height: 20px;" type="text"/>	<input style="width: 100%; height: 20px;" type="text"/>
5 ----	<input style="width: 100%; height: 20px;" type="text"/>	<input style="width: 100%; height: 20px;" type="text"/>
6 ----	<input style="width: 100%; height: 20px;" type="text"/>	<input style="width: 100%; height: 20px;" type="text"/>
7 ----	<input style="width: 100%; height: 20px;" type="text"/>	<input style="width: 100%; height: 20px;" type="text"/>
8 ----	<input style="width: 100%; height: 20px;" type="text"/>	<input style="width: 100%; height: 20px;" type="text"/>
9 ----	<input style="width: 100%; height: 20px;" type="text"/>	<input style="width: 100%; height: 20px;" type="text"/>
10----	<input style="width: 100%; height: 20px;" type="text"/>	<input style="width: 100%; height: 20px;" type="text"/>
11----	<input style="width: 100%; height: 20px;" type="text"/>	<input style="width: 100%; height: 20px;" type="text"/>
12----	<input style="width: 100%; height: 20px;" type="text"/>	<input style="width: 100%; height: 20px;" type="text"/>
13----	<input style="width: 100%; height: 20px;" type="text"/>	<input style="width: 100%; height: 20px;" type="text"/>
14----	<input style="width: 100%; height: 20px;" type="text"/>	<input style="width: 100%; height: 20px;" type="text"/>